









*PLC*  
*BOMBAS DE ENGRANAJES*  
*GEAR PUMPS*

***Roquet***  
*making moves*

<b>Empresa</b> .....	3
<b>Información general</b> .....	4
<b>Bomba de engranajes PLC</b> 	
Datos técnicos .....	5
Sistema de codificación.....	7
Tipos de ejes motriz.....	8
Tipos de conexión tomas.....	8
Tipos de tapas frontales .....	9
Tapa tipo 01 .....	10
Tapa tipo 10 .....	11
Tapa tipo 23 .....	12
Tapa tipo 09 .....	13
<b>Bomba de engranajes PLJ (PLC+PLC)</b> 	
Tapa tipo 10 .....	14
<b>Bomba de engranajes PLK (PLC+PLA)</b> 	
Tapa tipo 10 .....	15
<b>Bomba de engranajes PLH (PLC+L)</b> 	
Tapa tipo 10 .....	16
<b>Bomba de engranajes PLZ (PLC+L0)</b> 	
Tapa tipo 10 .....	17
<b>Otras opciones</b> 	
13PLC y 14PLC - Tapa tipo 09 .....	18
Tapa trasera para bombas reversibles.....	18
<b>Recambios</b>	
Bomba PLC.....	19
Bomba PLJ (PLC+PLC) .....	20
Bomba PLK (PLC+PLA) .....	21
Bomba PLH (PLC+L).....	22
Bomba PLZ (PLC+L0).....	23

<b>Company</b> .....	3
<b>Information</b> .....	4
<b>Gear pump PLC</b> 	
Technical data .....	5
Coding system .....	7
Drive shaft forms .....	8
Port connection forms .....	8
Front flange types .....	9
Front flange type 01 .....	10
Front flange type 10.....	11
Front flange type 23.....	12
Front flange type 09 .....	13
<b>Gear pump PLJ (PLC+PLC)</b> 	
Front flange type 10.....	14
<b>Gear pump PLK (PLC+PLA)</b> 	
Front flange type 10.....	15
<b>Gear pump PLH (PLC+L)</b> 	
Front flange type 10.....	16
<b>Gear pump PLZ (PLC+L0)</b> 	
Front flange type 10.....	17
<b>Others options</b> 	
13PLC & 14PLC - Front flange type 09.....	18
Back cover for reversible pumps.....	18
<b>Spare parts</b>	
Gear pump PLC .....	19
Gear pump PLJ (PLC+PLC).....	20
Gear pump PLK (PLC+PLA).....	21
Gear pump PLH (PLC+L) .....	22
Gear pump PLZ (PLC+L0).....	23

**HISTORIA** Más de medio siglo de trayectoria especializada en oleodinámica. Roquet es proveedor internacional en los sectores agrícola, naval, manutención, máquina-herramienta, automoción pesada, maquinaria de obras públicas, minería, eólica, alimentación, etc. Marca líder en España y una referencia importante en el ámbito internacional.

**TECNOLOGÍA** Roquet dispone de un importante departamento de diseño y desarrollo, con bancos de prueba de fatiga, nivel sonoro, resistencia a la corrosión, etc, apoyados por un avanzado laboratorio metalográfico. Se realizan grandes inversiones en centros de mecanizado de última generación para mantener una óptima calidad-productividad. La mayoría de piezas críticas (correderas, piezas de fundición, ejes de bomba, etc) se fabrican íntegramente en la propia empresa.

**FIABILIDAD** Una extensa gama de productos robustos y resistentes. Diseñados para rendir, contruidos para durar. Todas las gamas de productos se someten a pruebas de vida en condiciones de trabajo realistas durante el diseño y desarrollo del producto. De esta forma se asegura su perfecta adaptación a las diversas aplicaciones finales tales como tractores, carretillas elevadoras, palas cargadoras, excavadoras, grúas, volquetes, muelles de carga... Se prueba el 100% de las unidades producidas, según procedimientos internos de prueba, antes de la expedición.

**CAPACIDAD** 400 profesionales en plantilla. Cinco plantas de producción con una superficie cubierta de 40.000 m<sup>2</sup>. Producción actual: 180.000 bombas, 300.000 cuerpos de distribuidor y 500.000 cilindros. Una red comercial de distribución extendida por más de 35 países de los 5 continentes.

**HISTORY** Over fifty years experience in fluid power. Supplier to international manufactures of agricultural, construction, mining, mechanical handling, machine-tool and food machinery. Main supplier to the Spanish market with rapidly increasing presence in European and world markets.

**TECHNOLOGY** Roquet has a large design and development department with substantial fatigue, noise, corrosion-resistance, cleanliness and testing facilities, backed by a well-equipped metallurgical laboratory.

**RELIABILITY** A broad range of robust products: designed to perform, built to last. All products ranges life-tested under realistic conditions during development to ensure their suitability for use in applications such as tractors, fork-lift trucks, loaders, excavators, cranes, dumpers, dock-levellers... Each and every product tested to a stringent test specification prior to shipment.

**CAPABILITY** 400 well trained employees. Five factories with a total floor area of 40.000m<sup>2</sup> Current production 180.000 pumps, 300.000 control valve bodies and 500.000 cylinders. Distribution network in over 35 countries.

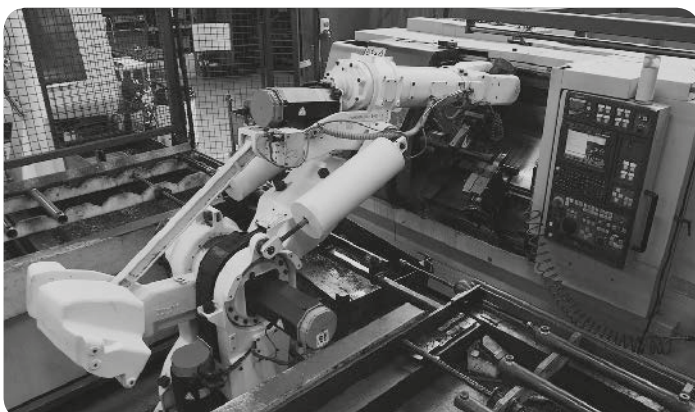

Nuestras bombas están equilibradas hidrostáticamente y provistas de reajuste lateral automático.

Se recomienda el empleo de aceite para instalaciones oleodinámicas con aditivos antiespumantes y de extrema presión.

Para obtener una larga vida, tanto del aceite como de la bomba es preciso trabajar entre una viscosidad de 20 - 80 cSt, según presiones de trabajo a una temperatura de 50° C.

Gama de temperaturas del fluido hidráulico +5° C +80° C.

El apartado de filtraje es muy importante, ya que la mayoría de averías son debidas a la suciedad del aceite. Ver datos técnicos.

La mejor forma de accionamiento es de conexión directa por medio de un acoplamiento elástico, que permite un movimiento mínimo radial y axial de 0,3 a 0,4 mm, por lo que de esta forma quedarán absorbidas todas las vibraciones del motor que tanto perjudican la buena marcha de la bomba. Los conductos de aspiración serán lo suficientemente dimensionados para que la depresión no exceda de 0,3 bars. Conexión por bridas S.A.E. o rosca G.

Sentido de giro derecha o izquierda, mirando la bomba por el lado del eje. Antes de poner por primera vez la bomba en marcha, asegurarse que el sentido de giro es el correcto.

Presentamos en el apartado de bombas dobles, varios tipos de fijación con sus ejes más normales. No obstante se podrán construir bombas dobles con las mismas fijaciones que las simples y sus ejes correspondientes.

Estas consideraciones también son validas para bombas triples y cuadruples, que podemos fabricar.

**NOTA IMPORTANTE: En versión estándar la conexión es de rosca G.**

Este catálogo muestra los productos en su configuración más estándar. Para diseños personalizados o especiales, deberá ponerse en contacto con ROQUETHYDRAULICS, S.L.

Las especificaciones y los datos de este catálogo no son susceptibles de interpretación. En caso de dudas, póngase en contacto con ROQUETHYDRAULICS, S.L.

ROQUETHYDRAULICS, S.L. se reserva el derecho de realizar modificaciones, actualizaciones o revisiones de este catálogo sin previo aviso.

ROQUETHYDRAULICS, S.L. no es responsable de ningún daño provocado por un uso incorrecto del producto.

*Our pumps are hydrostatically balanced and have automatic lateral adjustment.*

*We recommend the use of the oil for oil-dynamic installations with antifoaming additives and for extreme pressure.*

*To obtain extended pump life it is necessary to work with oil viscosities between 20 - 80 cSt, relating to working pressure and at a temperature of 50°C.*

*Oil temperature range +5°C - +80°C.*

*Filtration is extremely important since most problems are due to oil contamination.*

*The most efficient drive method is by means of axial flexible coupling, with minimum 0,3 - 0,4 mm. radial and axial movement, thus reducing the effects of vibration and maintaining maximum efficiency of the pump.*

*The suction pipes should be large enough to ensure that cavitation does not exceed 0,3 Bar. Connection by SAE flange or threaded G.*

*Rotation direction: Clockwise or anti-clockwise when facing the shaft end.*

*Before starting the pump, make sure the direction of rotation is correct.*

*Double and multiple pumps are available with all shafts and flanges shown for single pumps.*

**IMPORTANT NOTE: Side ports threaded G are available as standard version.**

*This Catalogue shows the product in the most standard configuration; customized or special designs are also available, please contact to ROQUETHYDRAULICS, S.L.*

*The specifications and data in this catalogue are not open to any interpretation, please contact with ROQUETHYDRAULICS, S.L. in case of doubt.*

*ROQUETHYDRAULICS, S.L. reserves the right to modify, update or revise this catalogue without prior notice.*

*ROQUETHYDRAULICS, S.L. is not responsible for any damage caused by an incorrect use of the product.*

**Partes de una bomba / Pump parts**

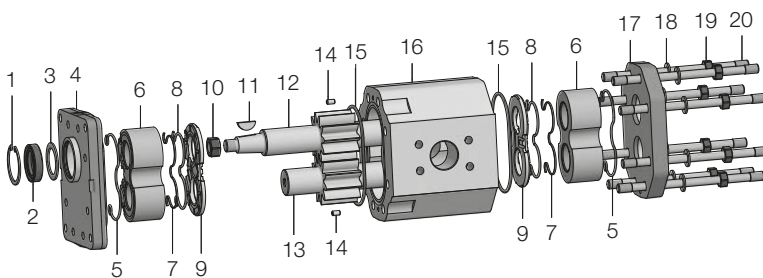

1	Anillo elástico Circlip	11	Chaveta Key
2	Retén aceite Oil seal	12	Rueda motriz Drive shaft
3	Anillo tope retén Shaft seal end ring	13	Rueda conducida Driven shaft
4	Tapa frontal Front flange	14	Pasador Pin
5	Junta apoyo cojinete O-ring	15	Junta de tope Housing gasket
6	Conjunto cojinete apoyo Bearing assembly	16	Cuerpo bomba Pump housing
7	Junta antiextrusión Anti-extrusion gasket	17	Tapa posterior Back cover
8	Junta de compensación Compensation gasket	18	Arandelas Washers
9	Plaqueta de compensación Thrust plate	19	Tuercas Nuts
10	Tuerca Nut	20	Espárragos Threaded rods

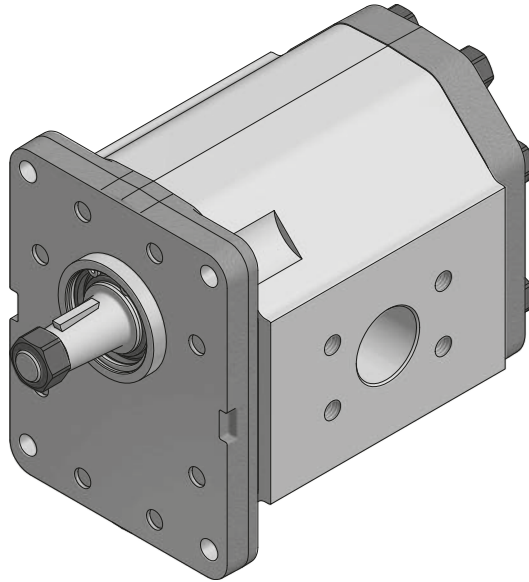

<b>Caudal bomba</b> <i>Pump flow rate</i>	L/min. 1500 R.P.M. (US. GPM 1500 RPM)	80 (21)	100 (26)	125 (33)	150 (40)	175 (46)	200 (53)	225 (59)
<b>Cilindrada</b> <i>Displacement</i>	cm <sup>3</sup> /v - cc/rev (in <sup>3</sup> /rev)	53,3 (3,25)	66,6 (4,06)	83,3 (5,08)	100 (6,10)	116,6 (7,12)	133,3 (8,13)	150 (9,15)
<b>Presión máx. continua en</b> <i>Cont. max. pressure</i>	bar (PSI)	225 (3265)					200 (2900)	175 (2540)
<b>Presión máx. inter 5 seg. max.</b> <i>Intermittent max. pressure</i>	bar (PSI)	250 (3625)					225 (3265)	200 (2900)
<b>R.P.M. máximas</b> <i>Max. R.P.M.</i>		3.000			2.500	2.000	1.750	
<b>Mínimas R.P.M. según presión</b> <i>Min. R.P.M. at given pressures</i>	100 bar (1450 PSI)	400			350			
	175 bar (2540 PSI)	450			400			
	250 bar (3625 PSI)	550			-	-	-	
<b>Aceite recomendado</b> <i>Fluid to be used</i>		ISO 6743 tipo HM, HV ó HG						
<b>Viscosidad</b> <i>Viscosity range</i>		ISO 3448 cat. VG32-VG46						
<b>Grado de limpieza del aceite</b> <i>Recommended fluid cleanliness</i>		19/16 s/. ISO 4406 ó RP70H						
<b>Temperatura de trabajo del aceite</b> <i>Oil temperature</i>		-20°C... +80°C -4°F... +176°F						
<b>Depresión máximo en aspiración</b> <i>Max. suction depression</i>		< 0,3 bar						

**CONEXIONES TIPO M**

ROQUET HYDRAULICS, S.L. utiliza conexiones tipo SAE J518 para el modelo de bomba tipo PLC.

**CONNECTION TYPE M**

ROQUET HYDRAULICS, S.L. uses connections type SAE J518 for the PLC gear pump model.

**ACCIONAMIENTO DE LAS BOMBAS**

Deben utilizarse acoplamientos entre bomba y accionamiento que eviten la transmisión de esfuerzos tanto axiales como laterales. Las bombas en su configuración estándar no admiten este tipo de esfuerzos, causando una disminución rápida de su vida útil.

**PUMP DRIVING DEVICES**

It must be used a driving device to avoid the transmission of axial and radial loads to the axis of the pump. Standard flanges and pumps are not designed to handle this loads and this causes a reduction of its working life.

**Gráfico de caudales, rendimientos y potencias según cilindrada**  
**Flow, performance and power chart according to displacement**

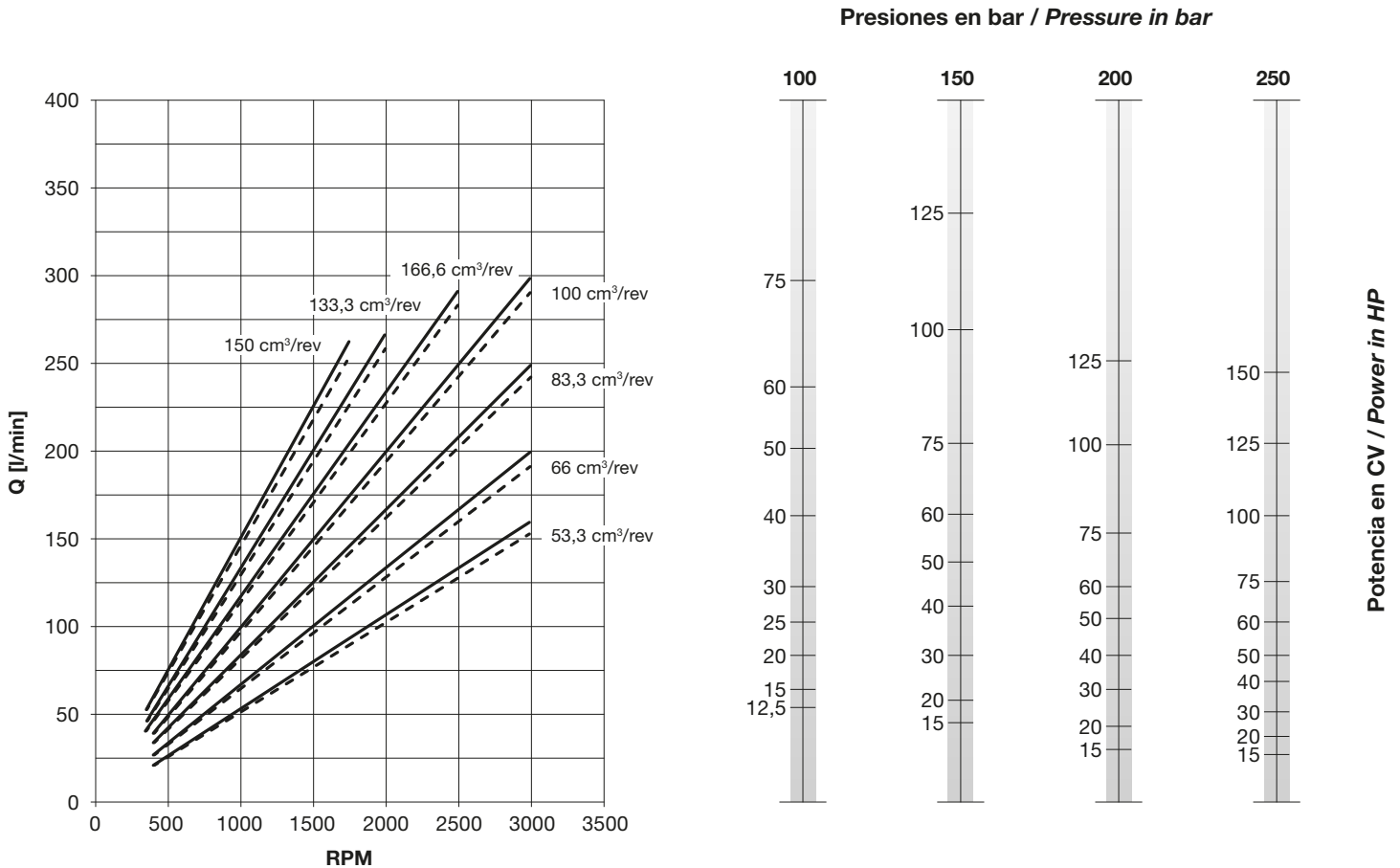

**NOTA:** Estos diagramas han sido obtenidos con un aceite de 4,5°E (37 cSt) de viscosidad y una temperatura de 50°C.  
**NOTE:** These results have been obtained with 4,5°E (37 cSt) viscosity oil and at 50 deg. C (122°F).

Sistema de codificación	1	PLC	125	D	E	10	M	-***	Coding system
-------------------------	---	-----	-----	---	---	----	---	------	---------------

Tipo / Type	
1	Sin polea / <i>Without pulley</i>
13	SAE C (2 taladros) con cojinete de apoyo <i>SAE C (2 holes) with support bearing</i>
14	SAE C (2 taladros) con dos retenes <i>SAE C (2 holes) with two oil seals</i>

Código / Code

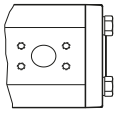
Formas conexión tomas <i>Port connection forms</i>
 M

Modelo / Model	
PLC	Simple / <i>Simple</i>
PLJ	Múltiple / <i>Multiple PLC+PLC</i>
PLK	Múltiple / <i>Multiple PLC+PLA</i>
PLH	Múltiple / <i>Multiple PLC+L</i>
PLZ	Múltiple / <i>Multiple PLC+L0</i>

Tipo de tapa / <i>Fixing flange</i>
01-09-10-23

Forma eje motriz / <i>Drive shaft form</i>
A-B-C-E-G-H-J

Caudal bomba a 1500 rpm y 0 bar <i>Pump flow rate at 1500 rpm and 0 bar</i>
Ver hoja técnica / <i>See technical data</i>

Sentido de giro / <i>Rotation direction</i>	
D	Derecha / <i>Clockwise</i>
I	Izquierda / <i>Counterclockwise</i>
R	Reversible / <i>Reversible</i>

### Tipos de eje motriz disponibles / Available drive shaft forms

**Eje forma A / Shaft form A**

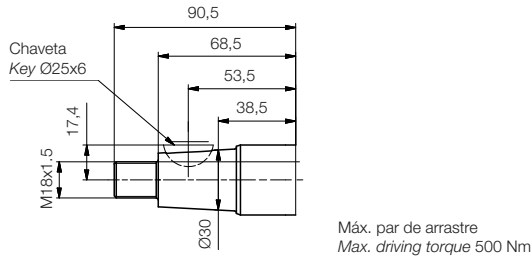

**Eje forma B / Shaft form B**

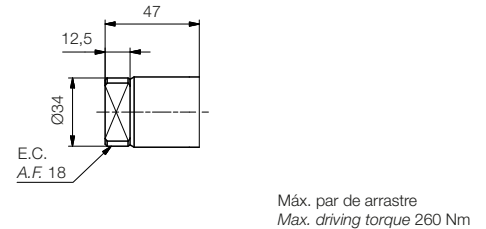

**Eje forma C / Shaft form C**

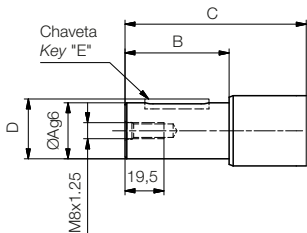

Caudal / Displacement [l/min at 1500 rpm]	A	B	C	D	E
80-150 l/min	28	52	139,5	29,9	5x8x32
175-225 l/min	30	70	157,5	31,9	5x8x50

Máx. par de arrastre  
Max. driving torque 400 Nm (80-150 l/min)  
650 Nm (175-225 l/min)

**Eje forma E / Shaft form E**

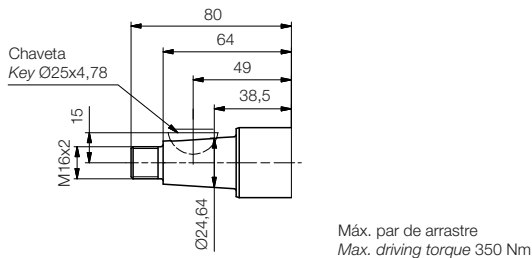

**Eje forma G / Shaft form G**

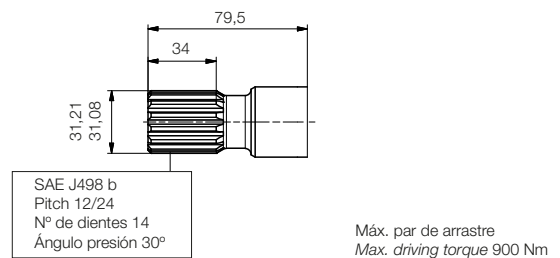

**Eje forma H / Shaft form H**

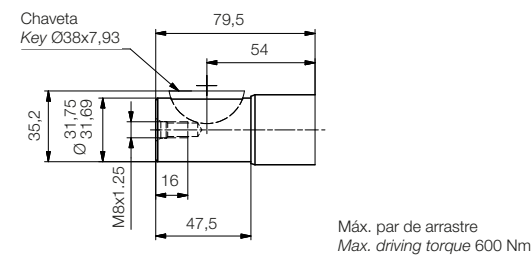

**Eje forma J / Shaft form J**

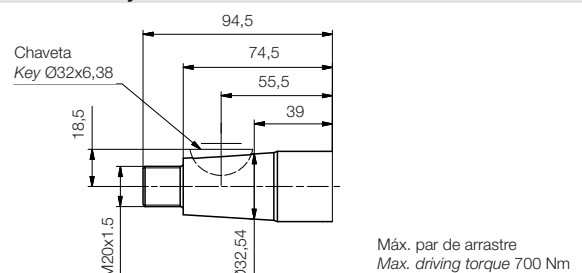

### Formas de conexión de tomas disponibles / Available port connection forms

Tomas M / M Ports	1 sentido de rotación / 1 rotation direction									
	Aspiración / Suction					Presión / Pressure				
Caudal / Flow (1500 rpm)	A	B	C	D	E	A	B	C	D	E
80 l/min ... 125 l/min	35,7	69,9	M12	38	-	30,2	58,7	M10	32	
150 l/min ... 225 l/min	42,9	77,8	M12	38	50	35,7	69,9	M12	38	

Tomas M / M Ports	Reversible			
Caudal / Flow (1500 rpm)	A	B	C	D
80 l/min ... 125 l/min	30,2	58,7	M10	32
150 l/min ... 225 l/min	35,7	69,9	M12	38

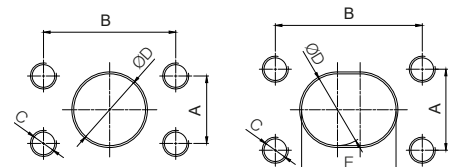



Tipos de tapas frontales disponibles / Available front flanges types

Tapa tipo 01 / Front flange type 01

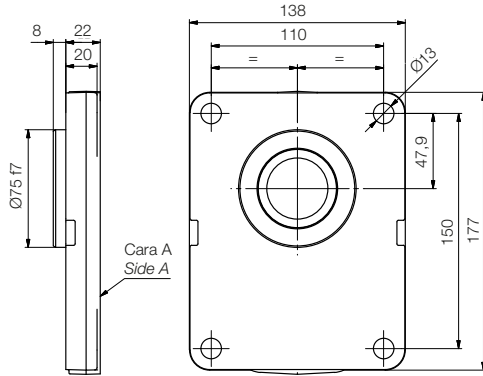

Tapa tipo 10 / Front flange type 10

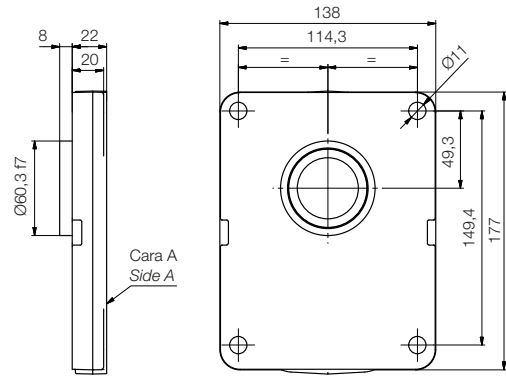

Tapa tipo 09 / Front flange type 09

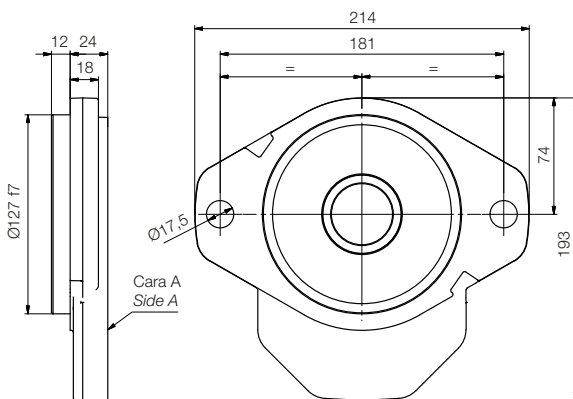

Tapa tipo 23 / Front flange type 23

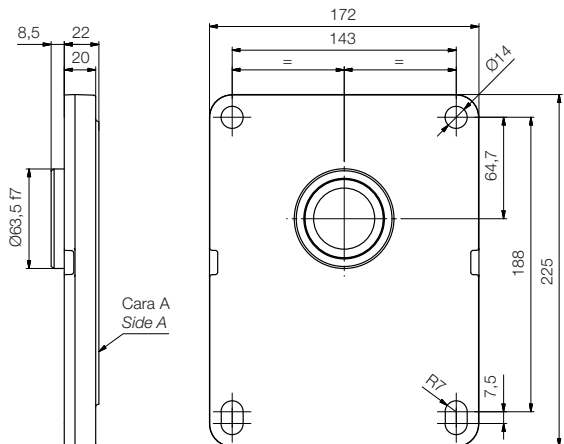

**Ejemplo:** Combinación de un eje tipo E y una tapa tipo 01  
**Example:** Combination of a E type shaft with a 01 type front flange

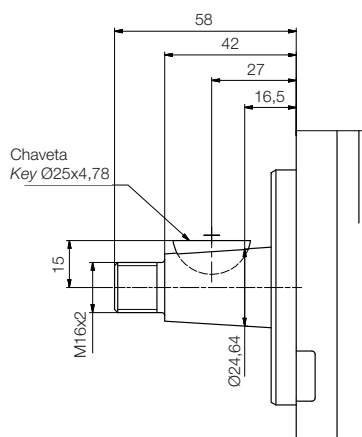

**NOTA:** La longitud del eje motriz varía en función del grosor de la tapa frontal.

**NOTE:** The useful length of the drive shaft varies depending on the front flange thickness.

### Tapa tipo 01 / Front flange type 01



### Eje forma A / Shaft form A

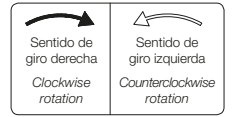
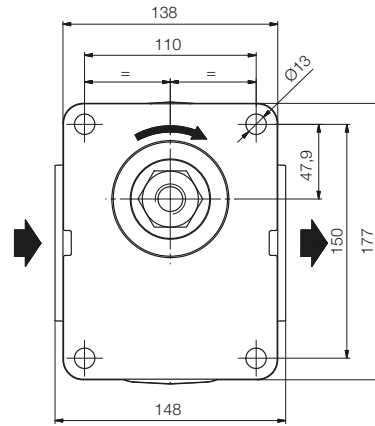
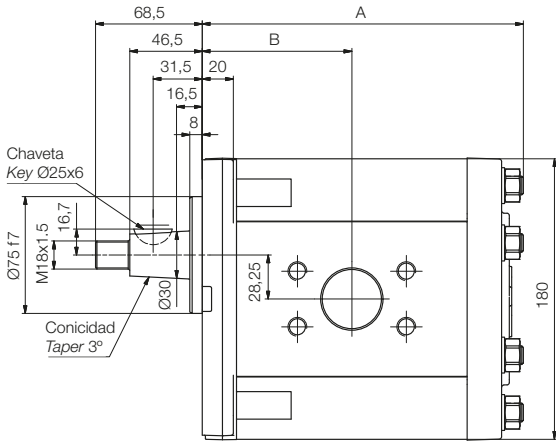

### Eje forma B / Shaft form B

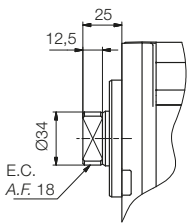

### Eje forma C / Shaft form C

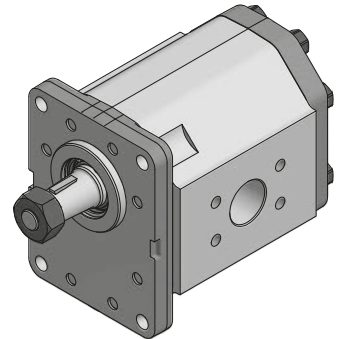
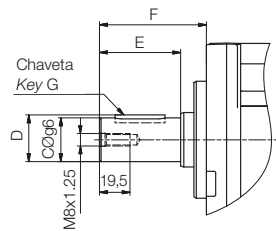

Caudal / Displacement [l/min at 1500 rpm]	C	D	E	F	G
80-150 l/min	28	29,9	52	68,5	5x8x32
175-250 l/min	30	31,9	70	86,5	5x8x50

Referencia Reference	Cilindrada cm <sup>3</sup> /rev Displacement cm <sup>3</sup> /rev	A	B	Peso kg Weight kg
1PLC80D▲01M	53,3	183	87,0	17,4
1PLC100D▲01M	66,6	190	87,0	17,9
1PLC125D▲01M	83,3	198	92,0	18,4
1PLC150D▲01M	100	206	96,0	19,0
1PLC175D▲01M	116,6	214	100,0	19,8
1PLC200D▲01M	133,3	223	104,0	20,6
1PLC225D▲01M	150	231	108,0	21,3

▲ Forma de eje / Shaft form.

**NOTA:** Para dimensiones y tipos de tomas disponibles de bombas de giro derecha (D), izquierda (I) o reversible (R), consultar página 8.  
**NOTE:** For dimensions and available port types of clockwise (D), counterclockwise (I) or reversible (R) rotation pumps, see page 8.

### Tapa tipo 10 / Front flange type 10

### Eje forma E / Shaft form E

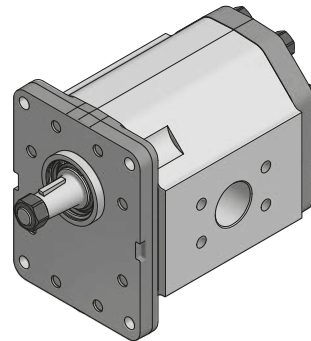
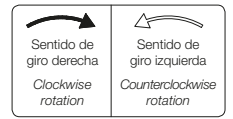
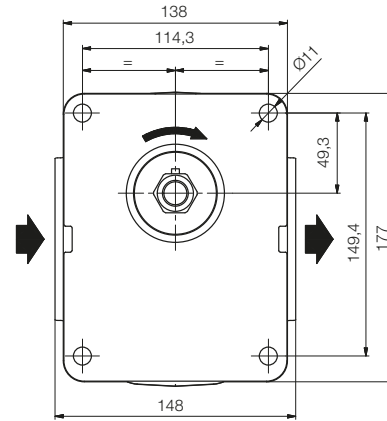
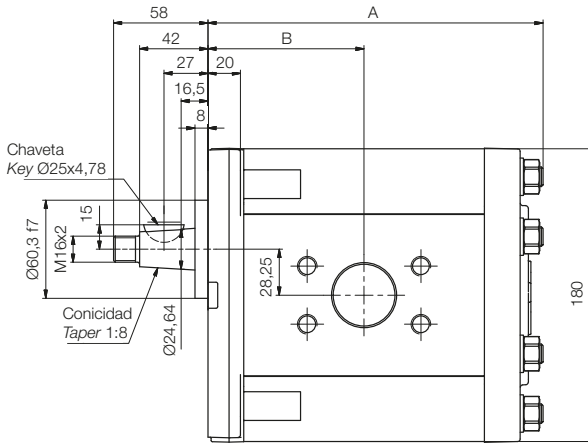

Referencia Reference	Cilindrada cm <sup>3</sup> /rev Displacement cm <sup>3</sup> /rev	A	B	Peso kg Weight kg
1PLC80DE10M	53,3	183	87,0	17,5
1PLC100DE10M	66,6	190	87,0	18,0
1PLC125DE10M	83,3	198	92,0	18,5
1PLC150DE10M	100	206	96,0	19,1
1PLC175DE10M	116,6	214	100,0	19,9
1PLC200DE10M	133,3	223	104,0	20,7
1PLC225DE10M	150	231	108,0	21,4

**NOTA:** Para dimensiones y tipos de tomas disponibles de bombas de giro derecha (D), izquierda (I) o reversible (R), consultar página 8.  
**NOTE:** For dimensions and available port types of clockwise (D), counterclockwise (I) or reversible (R) rotation pumps, see page 8.

### Tapa tipo 23 / Front flange type 23

### Eje forma J / Shaft form J

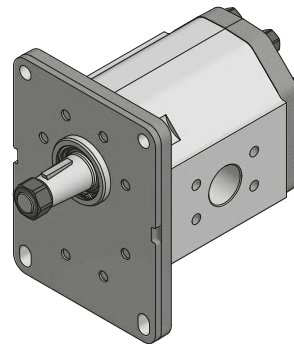
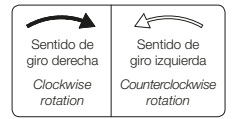
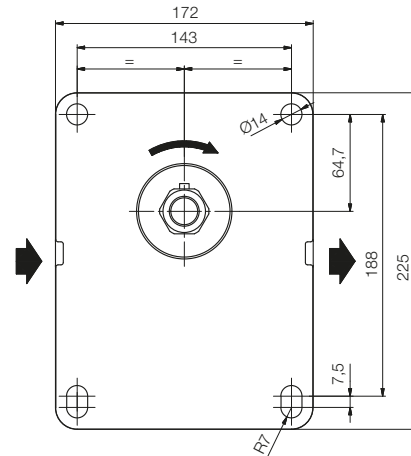
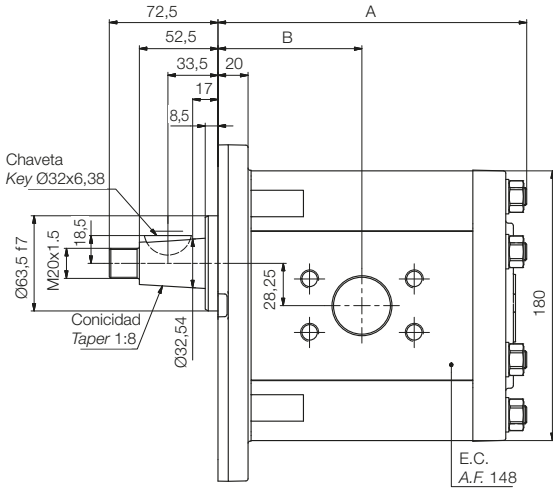

Referencia Reference	Cilindrada cm <sup>3</sup> /rev Displacement cm <sup>3</sup> /rev	A	B	Peso kg Weight kg
1PLC80DJ23M	53,3	183	87,0	17,7
1PLC100DJ23M	66,6	190	87,0	18,2
1PLC125DJ23M	83,3	198	92,0	18,7
1PLC150DJ23M	100	206	96,0	19,3
1PLC175DJ23M	116,6	214	100,0	20,1
1PLC200DJ23M	133,3	223	104,0	20,9
1PLC225DJ23M	150	231	108,0	21,6

**NOTA:** Para dimensiones y tipos de tomas disponibles de bombas de giro derecha (D), izquierda (I) o reversible (R), consultar página 8.  
**NOTE:** For dimensions and available port types of clockwise (D), counterclockwise (I) or reversible (R) rotation pumps, see page 8.

### Tapa tipo 09 / Front flange type 09

#### Eje forma G / Shaft form G

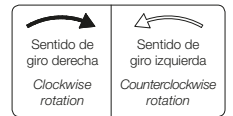
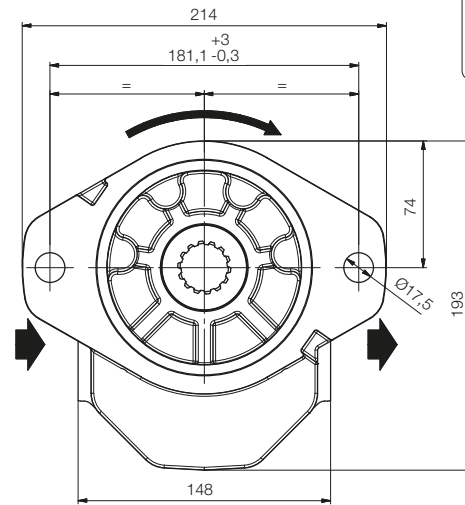
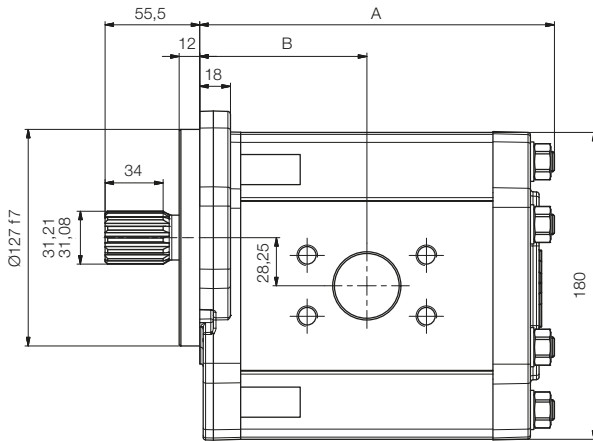

SAE Base plana  
Diametral pitch 12/24  
Ángulo de presión 30°  
Número de dientes 14  
Ajuste lateral

SAE flat base  
Diametral pitch 12/24  
Pressure angle 30°  
Teeth number 14  
Side fit

#### Eje forma H / Shaft form H

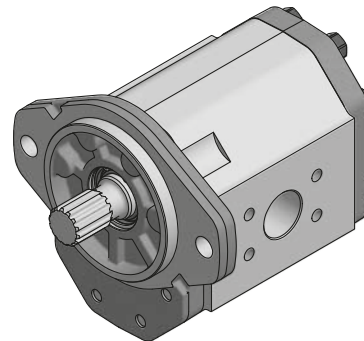
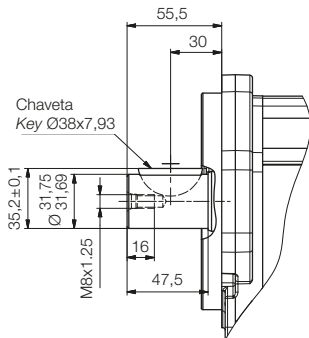

Referencia Reference	Cilindrada cm <sup>3</sup> /rev Displacement cm <sup>3</sup> /rev	A	B	Peso kg Weight kg
1PLC80D▲09M	53,3	185	89,0	17,6
1PLC100D▲09M	66,6	192	89,0	18,1
1PLC125D▲09M	83,3	200	94,0	18,6
1PLC150D▲09M	100	208	98,0	19,2
1PLC175D▲09M	116,6	216	102,0	20,0
1PLC200D▲09M	133,3	225	106,0	20,8
1PLC225D▲09M	150	233	110,0	21,5

▲ Forma de eje / Shaft form.

**NOTA:** Para dimensiones y tipos de tomas disponibles de bombas de giro derecha (D), izquierda (I) o reversible (R), consultar página 8.  
**NOTE:** For dimensions and available port types of clockwise (D), counterclockwise (I) or reversible (R) rotation pumps, see page 8.

### Tapa tipo 10 / Front flange type 10

### Eje forma E / Shaft form E

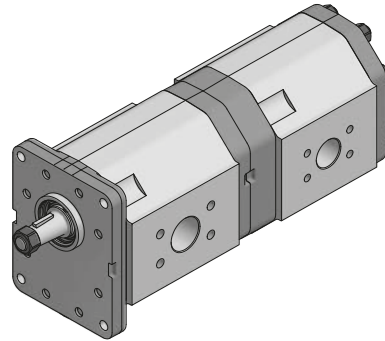
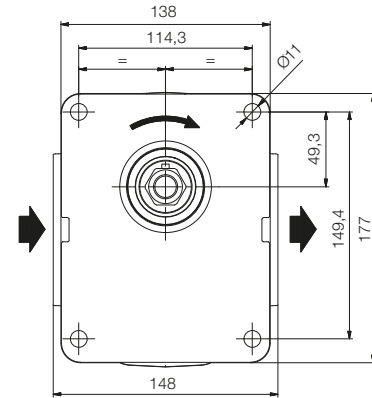
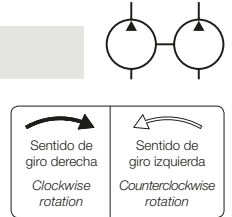
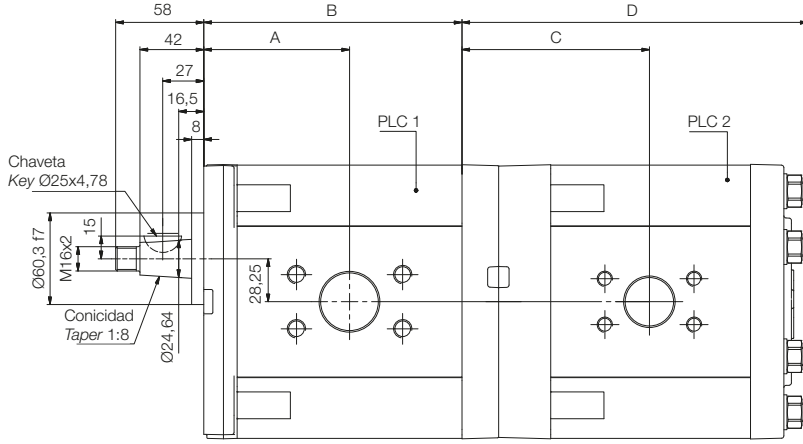

Para montajes de bombas de más de dos etapas, consultar con el departamento comercial. Máximo par de arrastre entre bombas 260 Nm.  
For more than two stages pump assemblies, contact the sales department. Maximum driving torque between stages 260 Nm.

La tabla siguiente hace referencia a la etapa frontal (PLC1) de la bomba múltiple PLJ.  
The following table refers to the front stage (PLC1) of the PLJ multiple pump.

Referencia Reference	Cilindrada Displacement cm <sup>3</sup> /rev	A	B	PLC1 - Peso kg PLC1 - Weight kg
1PLJ80-■DE10M	53,3	87,0	147,0	17,7
1PLJ100-■DE10M	66,6	87,0	153,5	18,2
1PLJ125-■DE10M	83,3	87,0	161,5	18,7
1PLJ150-■DE10M	100	96,0	170,0	19,3
1PLJ175-■DE10M	116,6	96,0	178,0	20,1
1PLJ200-■DE10M	133,3	96,0	186,5	20,9
1PLJ225-■DE10M	150	96,0	194,5	21,6

■ Caudal etapa posterior (PLC2). Ver tabla / Rear stage flow (PLC2). See table.

La tabla siguiente hace referencia a la etapa posterior (PLC2) de la bomba múltiple PLJ.  
The following table refers to the rear stage (PLC2) of the PLJ multiple pump.

■	Cilindrada Displacement cm <sup>3</sup> /rev	C	D	PLC2 - Peso kg PLC2 - Weight kg
80	53,3	123,5	219,5	17,7
100	66,6	123,5	226,0	18,2
125	83,3	123,5	234,0	18,7
150	100	132,5	242,5	19,3
175	116,6	132,5	250,5	20,1
200	133,3	132,5	259,0	20,9
225	150	132,5	267,0	21,6

### Ejemplo referencia comercial bomba PLJ Part number example PLJ pump

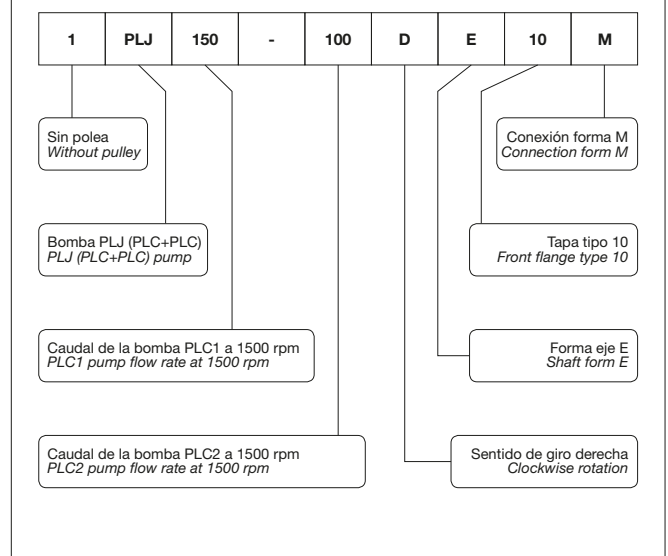

**NOTA:** Para dimensiones y tipos de tomas disponibles de bombas de giro derecha (D), izquierda (I) o reversible (R), consultar página 8.  
**NOTE:** For dimensions and available port types of clockwise (D), counterclockwise (I) or reversible (R) rotation pumps, see page 8.

Tapa tipo 10 / Front flange type 10

Eje forma E / Shaft form E

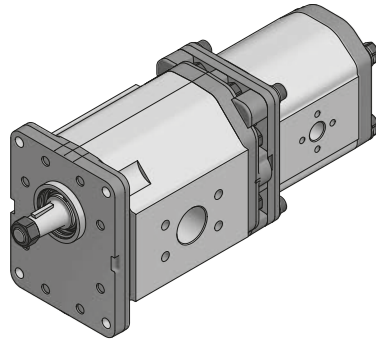
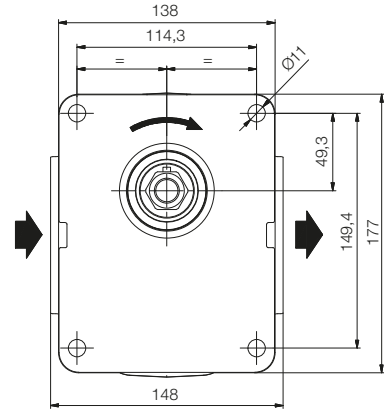
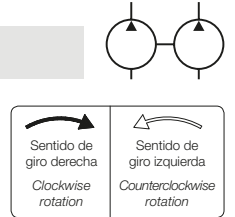
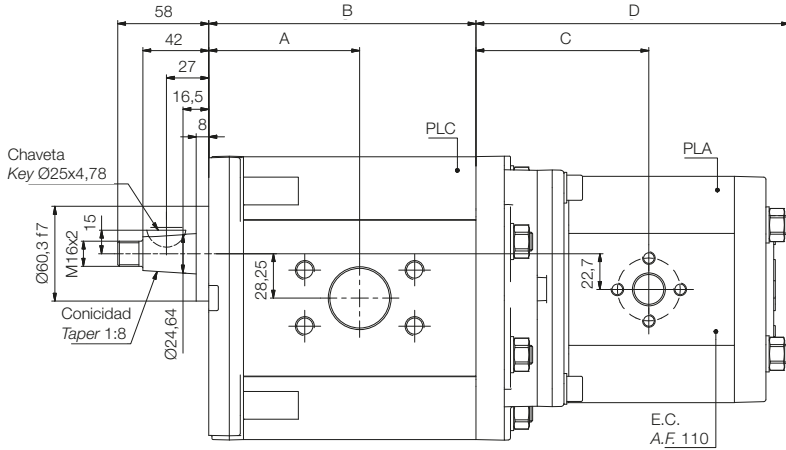

Para montajes de bombas de más de dos etapas, consultar con el departamento comercial. Máximo par de arrastre entre bombas 120 Nm.  
For more than two stages pump assemblies, contact the sales department. Maximum driving torque between stages 120 Nm.

La tabla siguiente hace referencia a la etapa frontal (PLC) de la bomba múltiple PLK.  
The following table refers to the front stage (PLC) of the PLK multiple pump.

Referencia Reference	Cilindrada Displacement cm <sup>3</sup> /rev	A	B	PLC - Peso kg PLC - Weight kg
1PLK80-■DE10MB	53,3	87,0	147,0	17,7
1PLK100-■DE10MB	66,6	87,0	153,5	18,2
1PLK125-■DE10MB	83,3	87,0	161,5	18,7
1PLK150-■DE10MB	100	96,0	170,0	19,3
1PLK175-■DE10MB	116,6	96,0	178,0	20,1
1PLK200-■DE10MB	133,3	96,0	186,5	20,9
1PLK225-■DE10MB	150	96,0	194,5	21,6

■ Caudal etapa posterior (PLA). Ver tabla / Rear stage flow (PLA). See table.

La tabla siguiente hace referencia a la etapa posterior (PLA) de la bomba múltiple PLK.  
The following table refers to the rear stage (PLA) of the PLK multiple pump.

■	Cilindrada Displacement cm <sup>3</sup> /rev	C	D	PLA - Peso kg PLA - Weight kg
27	18	108,9	168,0	8,3
36	24	116,9	173,0	8,6
45	30	121,9	178,0	8,9
54	36	121,9	183,0	9,1
66	44	121,9	189,5	9,5
75	50	121,9	194,5	9,7
84	56	121,9	199,6	10,0

Ejemplo referencia comercial bomba PLK  
Part number example PLK pump

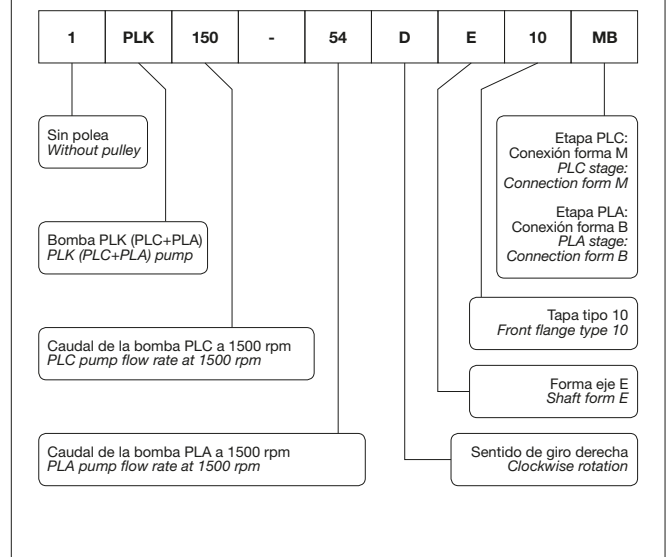

**NOTAS:** Bomba PLC: para dimensiones y tipos de tomas disponibles de bombas de giro derecha (D), izquierda (I) o reversible (R), consultar página 8.  
Bomba PLA: para dimensiones y tipos de toma disponibles consultar catálogo PLA.  
**NOTES:** PLC pump: for dimensions and available port types of clockwise (D), counterclockwise (I) or reversible (R) rotation pumps, see page 8.  
PLA pump: for dimensions and port types see PLA catalog.

### Tapa tipo 10 / Front flange type 10

### Eje forma E / Shaft form E

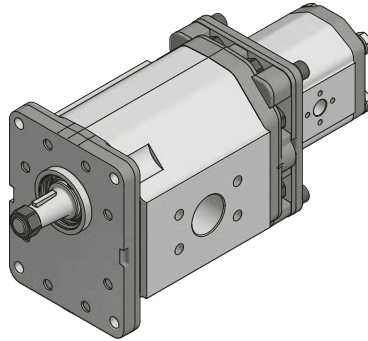
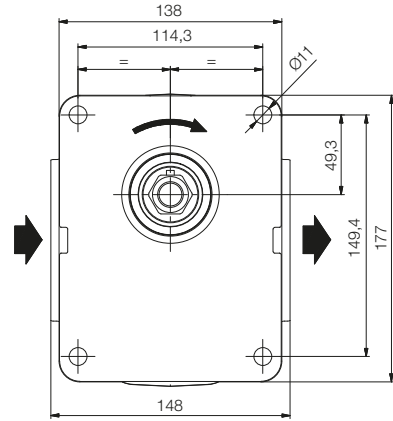
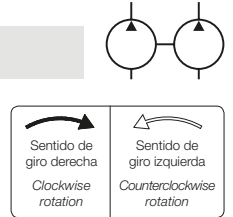
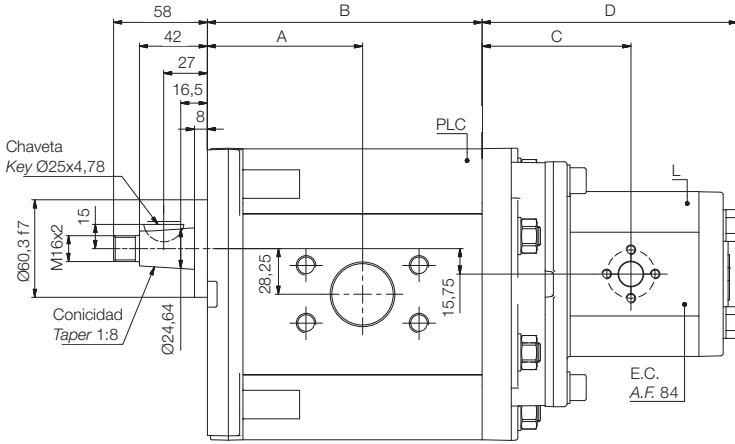

Para montajes de bombas de más de dos etapas, consultar con el departamento comercial. Máximo par de arrastre entre bombas 65 Nm.  
 For more than two stages pump assemblies, contact the sales department. Maximum driving torque between stages 65 Nm.

La tabla siguiente hace referencia a la etapa frontal (PLC) de la bomba múltiple PLH.  
 The following table refers to the front stage (PLC) of the PLH multiple pump.

Referencia Reference	Cilindrada Displacement cm <sup>3</sup> /rev	A	B	PLC - Peso kg PLC - Weight kg
1PLH80-■DE10MB	53,3	87,0	147,0	17,7
1PLH100-■DE10MB	66,6	87,0	153,5	18,2
1PLH125-■DE10MB	83,3	87,0	161,5	18,7
1PLH150-■DE10MB	100	96,0	170,0	19,3
1PLH175-■DE10MB	116,6	96,0	178,0	20,1
1PLH200-■DE10MB	133,3	96,0	186,5	20,9
1PLH225-■DE10MB	150	96,0	194,5	21,6

■ Caudal etapa posterior (L). Ver tabla / Rear stage flow (L). See table.

La tabla siguiente hace referencia a la etapa posterior (L) de la bomba múltiple PLH.  
 The following table refers to the rear stage (L) of the PLH multiple pump.

■	Cilindrada Displacement cm <sup>3</sup> /rev	C	D	L - Peso kg L - Weight kg
6	4	78,0	126,1	3,2
9	6	78,0	130,6	3,3
12	8	80,1	133,5	3,4
16	10,6	84,5	138,2	3,5
18	12	84,5	139,8	3,6
22	14,6	84,5	144,1	3,7
24	16	84,5	146,3	3,8
27	18	84,5	148,8	3,9
35	23,3	92,0	157,8	4,1
40	26,6	99,5	161,8	4,3

### Ejemplo referencia comercial bomba PLH Part number example PLH pump

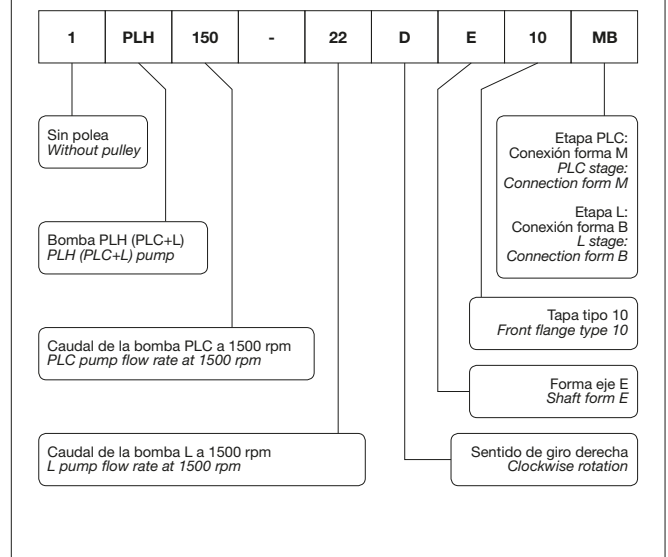

**NOTAS: Bomba PLC:** para dimensiones y tipos de tomas disponibles de bombas de giro derecha (D), izquierda (I) o reversible (R), consultar página 8.  
**Bomba L:** para dimensiones y tipos de toma disponibles consultar catálogo L.

**NOTES: PLC pump:** for dimensions and available port types of clockwise (D), counterclockwise (I) or reversible (R) rotation pumps, see page 8.  
**L pump:** for dimensions and port types see L catalog.



### Tapa tipo 10 / Front flange type 10

### Eje forma E / Shaft form E

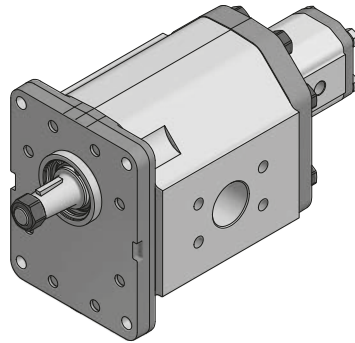
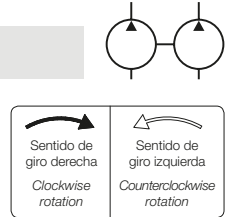
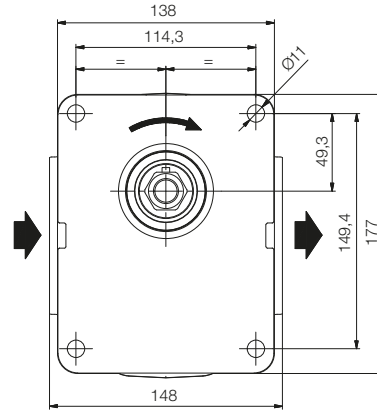
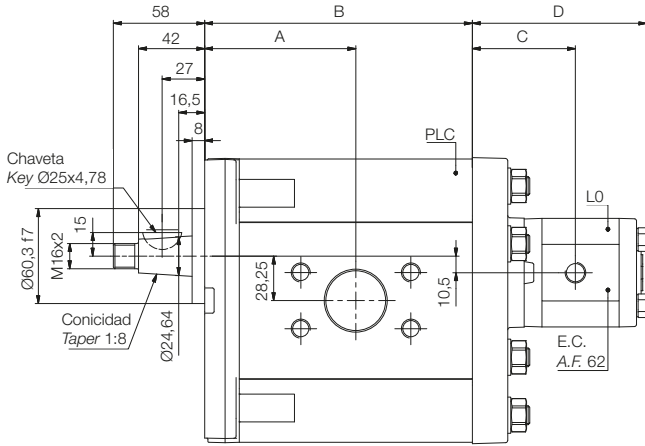

Para montajes de bombas de más de dos etapas, consultar con el departamento comercial. Máximo par de arrastre entre bombas 25 Nm.  
For more than two stages pump assemblies, contact the sales department. Maximum driving torque between stages 25 Nm.

La tabla siguiente hace referencia a la etapa frontal (PLC) de la bomba múltiple PLZ.  
The following table refers to the front stage (PLC) of the PLZ multiple pump.

Referencia Reference	Cilindrada Displacement cm <sup>3</sup> /rev	A	B	PLC - Peso kg PLC - Weight kg
1PLZ80-■DE10MR	53,3	87,0	147,0	17,7
1PLZ100-■DE10MR	66,6	87,0	153,5	18,2
1PLZ125-■DE10MR	83,3	87,0	161,5	18,7
1PLZ150-■DE10MR	100	96,0	170,0	19,3
1PLZ175-■DE10MR	116,6	96,0	178,0	20,1
1PLZ200-■DE10MR	133,3	96,0	186,5	20,9
1PLZ225-■DE10MR	150	96,0	194,5	21,6

■ Caudal etapa posterior (L0). Ver tabla / Rear stage flow (L0). See table.

La tabla siguiente hace referencia a la etapa posterior (L0) de la bomba múltiple PLZ.  
The following table refers to the rear stage (L0) of the PLZ multiple pump.

■	Cilindrada Displacement cm <sup>3</sup> /rev	C	D	L - Peso kg L - Weight kg
1,5	1	62,0	98,8	1,2
3	2	62,0	103,8	1,3
5	3,3	65,5	110,8	1,4
7,5	5	68,5	118,3	1,5
10	6,6	73,8	127,8	1,6

### Ejemplo referencia comercial bomba PLZ Part number example PLZ pump

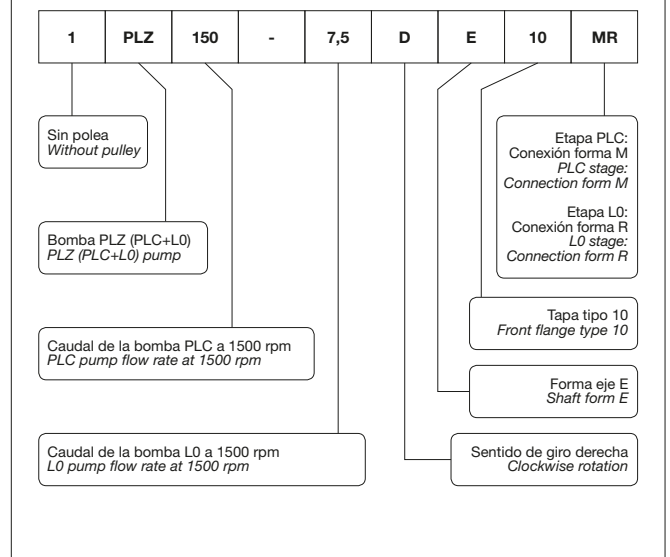

**NOTAS: Bomba PLC:** para dimensiones y tipos de tomas disponibles de bombas de giro derecha (D), izquierda (I) o reversible (R), consultar página 8.  
**Bomba L0:** para dimensiones y tipos de toma disponibles consultar catálogo L0.  
**NOTES: PLC pump:** for dimensions and available port types of clockwise (D), counterclockwise (I) or reversible (R) rotation pumps, see page 8.  
**L0 pump:** for dimensions and port types see L0 catalog.

13 PLC y 14 PLC - Tapa tipo 09 / 13 PLC & 14 PLC - Front flange type 09

Eje forma G / Shaft form G

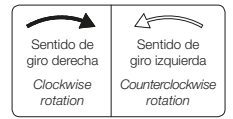
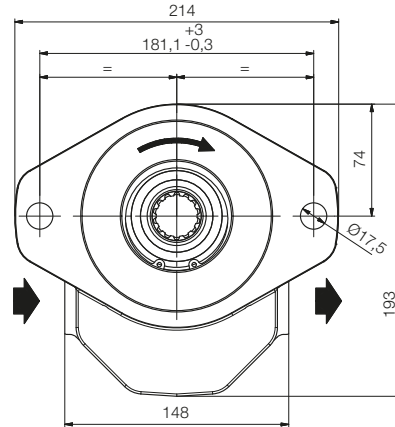
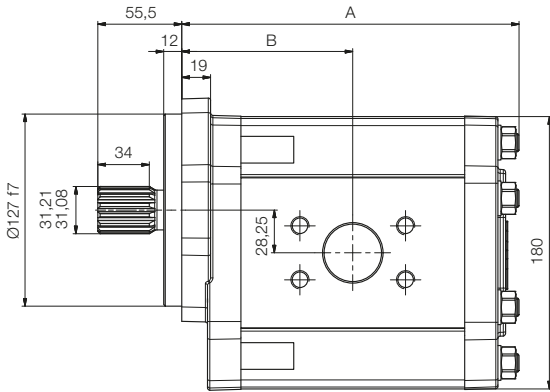

SAE Base plana  
Diametral pitch 12/24  
Ángulo de presión 30°  
Número de dientes 14  
Ajuste lateral

SAE flat base  
Diametral pitch 12/24  
Pressure angle 30°  
Teeth number 14  
Side fit

Eje forma H / Shaft form H

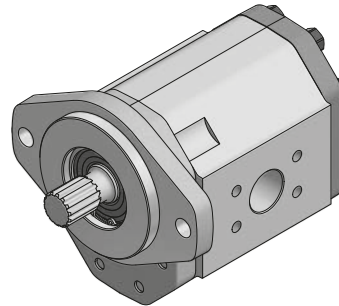
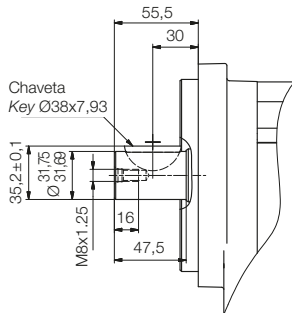

Referencia Reference	Cilindrada cm <sup>3</sup> /rev Displacement cm <sup>3</sup> /rev	A	B	Peso kg Weight kg
■ PLC80D▲09M	53,3	200	104	15,6
■ PLC100D▲09M	66,6	207	104	16,1
■ PLC125D▲09M	83,3	215	109	16,6
■ PLC150D▲09M	100	223	113	17,2
■ PLC175D▲09M	116,6	231	117	18,0
■ PLC200D▲09M	133,3	240	121	18,8
■ PLC225D▲09M	150	248	125	19,5

**NOTA:** Para dimensiones y tipos de tomas disponibles de bombas de giro derecha (D), izquierda (I) o reversible (R), consultar página 8.

**NOTE:** For dimensions and available port types of clockwise (D), counterclockwise (I) or reversible (R) rotation pumps, see page 8.

- 13 Retén y cojinete / Oil seal and bearing.
- 14 Dos retenes / Two oil seals.
- ▲ Forma de eje / Shaft form.

Tapa trasera para bombas reversibles  
Back cover for reversible pumps

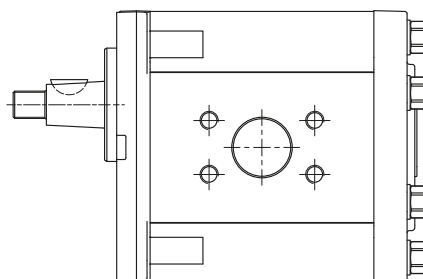
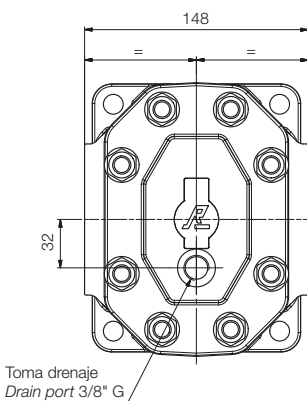
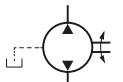

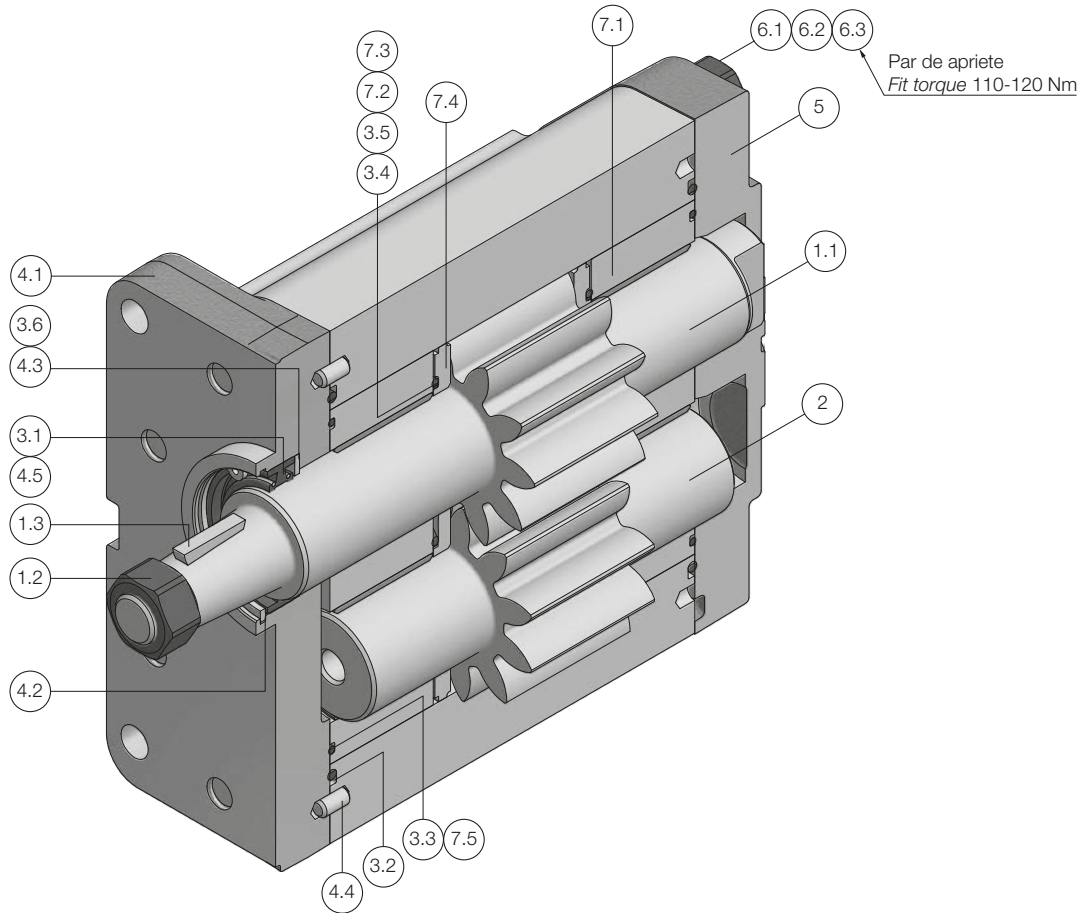

Nº de kit Kit number	Descripción Description	Piezas Parts
1	Kit eje motriz Drive shaft kit	
2	Eje conducido Driven shaft	
3	Kit juntas Seals kit	
4	Kit tapa delantera Front flange kit	

Nº de kit Kit number	Descripción Description	Piezas Parts
5	Tapa posterior Back cover	
6	Kit tornillos fijación Fixing screws kit	
7	Kit cojinetes apoyo Bearing assemblies kit	

**NOTA:** Consultar las referencias disponibles con el departamento comercial.  
**NOTE:** For available references contact the sales department.

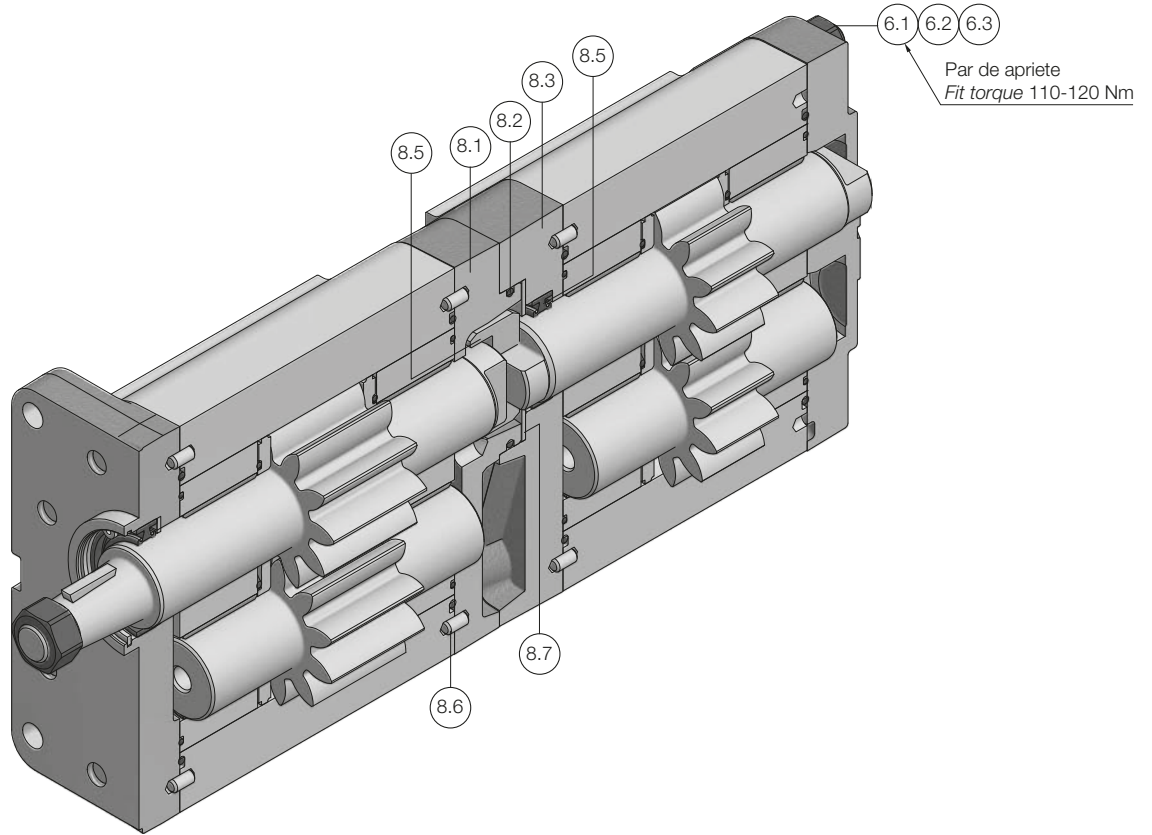

Nº de kit Kit number	Descripción Description	Piezas Parts
6	Kit tornillos fijación Fixing screws kit	

Nº de kit Kit number	Descripción Description	Piezas Parts
8	Kit tapas intermedias Intermediate flanges kit	

**NOTA:** Se puede crear una bomba doble PLJ uniendo una bomba de referencia estándar y una bomba estándar con eje tipo L y tapa frontal tipo 26. Se ofrece el kit de tapas intermedias y el kit del eje tipo L para poder transformar la bomba.

**NOTE:** A PLJ double pump can be assembled from a pump with standard reference and a pump with shaft form L and front flange type 26. The intermediate flanges kit and the L shaft kit are offered in order to transform the pump.

**Bomba delantera estándar**  
Standard front pump

Ejemplo  
Example 1PLC150DE10M

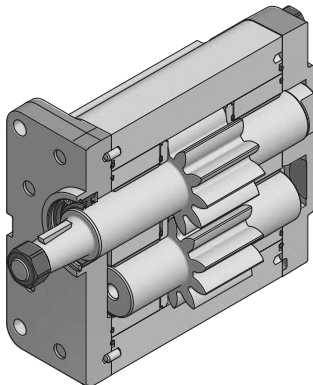

**Bomba trasera con eje tipo L y tapa tipo 26**  
Rear pump with shaft form L and front flange type 26

Ejemplo  
Example 1PLC100DL26M

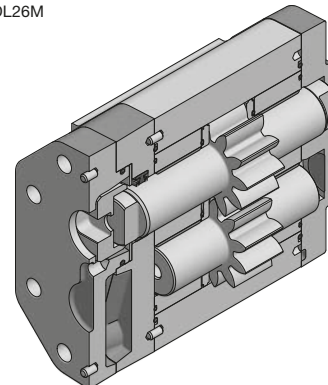

**NOTA:** Consultar las referencias disponibles con el departamento comercial. / **NOTE:** For available references contact the sales department.

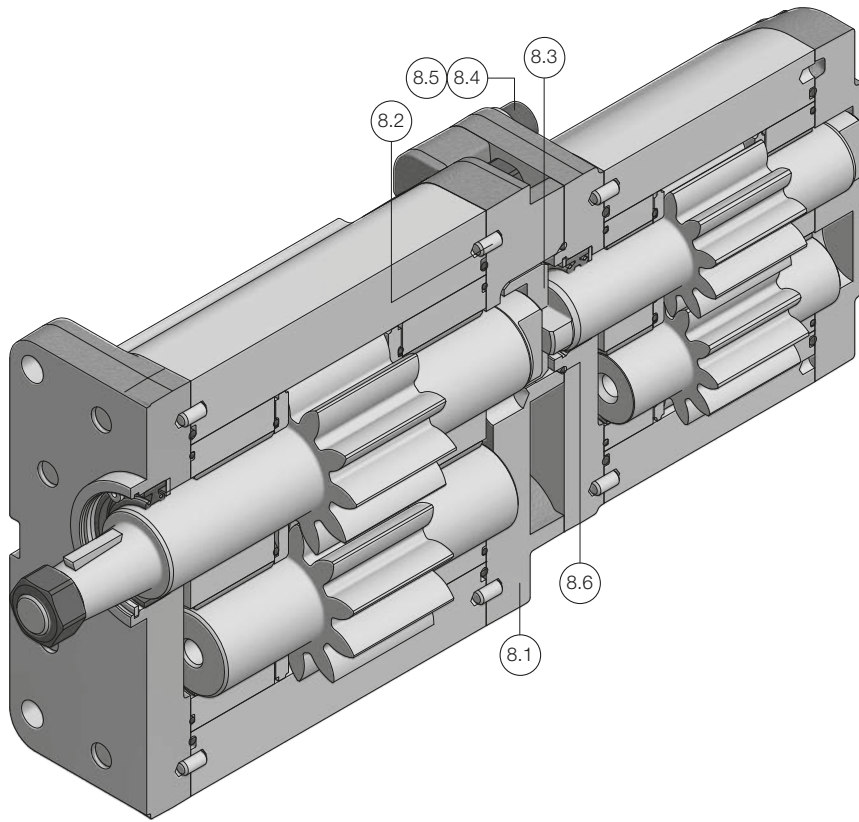

Nº de kit <i>Kit number</i>	Descripción <i>Description</i>	Piezas <i>Parts</i>
8	Kit tapas intermedias <i>Intermediate flanges kit</i>	

**NOTA:** Se puede crear una bomba doble PLK uniendo una bomba PLC estándar, un kit de tapa intermedia y una bomba PLA estándar con eje tipo B y tapa frontal tipo 10.

**NOTE:** A PLK double pump can be assembled from a standard PLC pump, an intermediate flange kit and a standard PLA pump with shaft form B and front flange type 10.

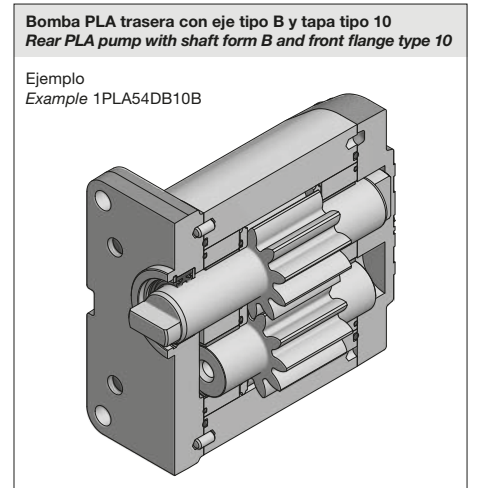
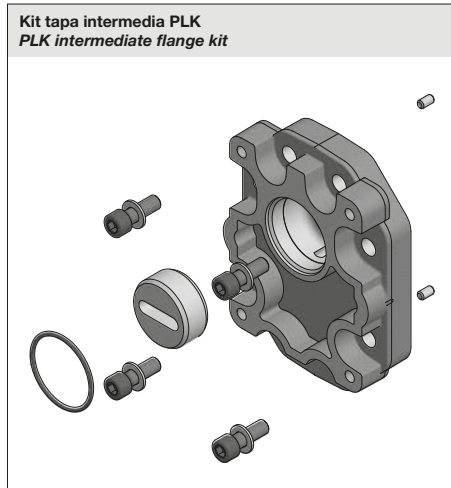
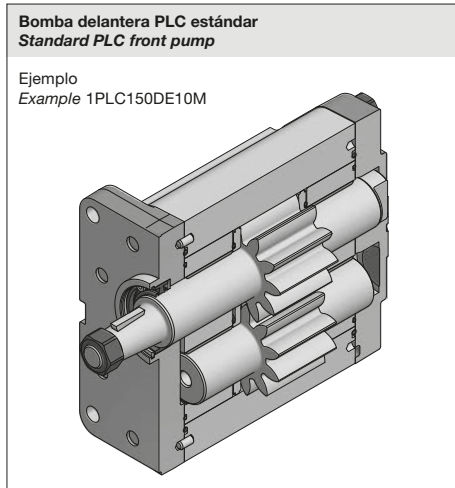

**NOTA:** Consultar las referencias disponibles con el departamento comercial. / **NOTE:** For available references contact the sales department.

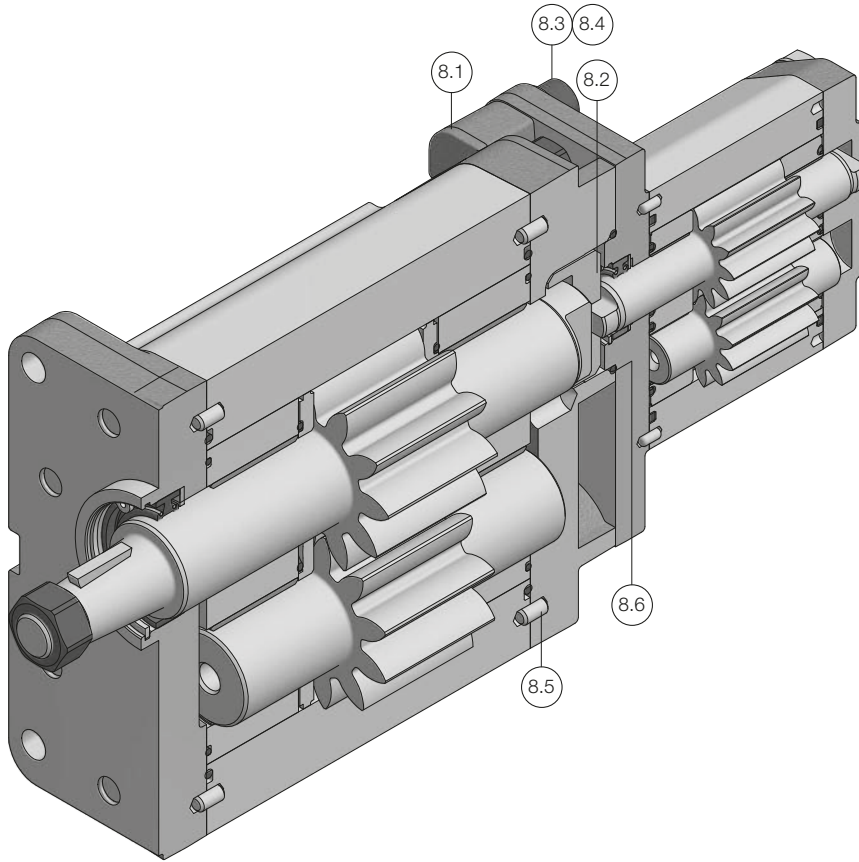

Nº de kit Kit number	Descripción Description	Piezas Parts
8	Kit tapa intermedia Intermediate flange kit	

**NOTA:** Se puede crear una bomba doble PLH uniendo una bomba PLC estándar, un kit de tapa intermedia y una bomba L estándar con eje tipo B y tapa frontal tipo 24.

**NOTE:** A PLH double pump can be assembled from a standard PLC pump, an intermediate flange kit and a standard L pump with shaft form B and front flange type 24.

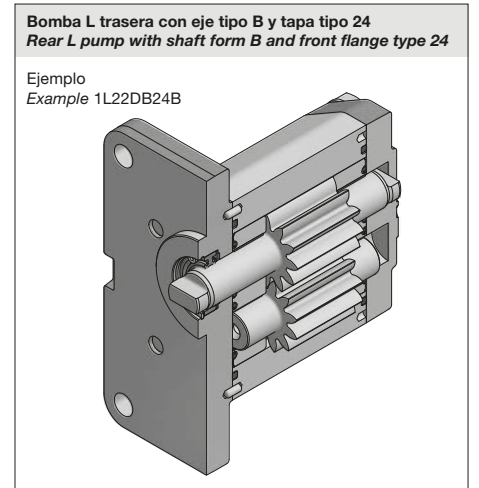
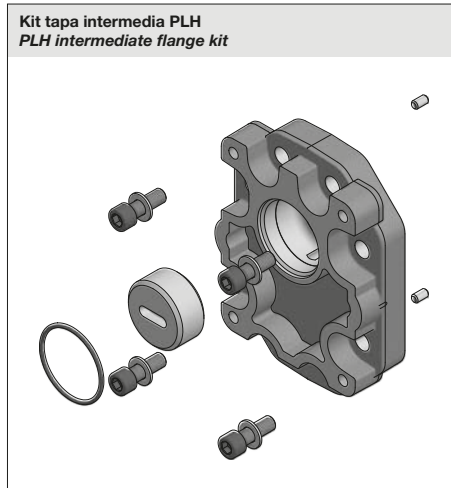
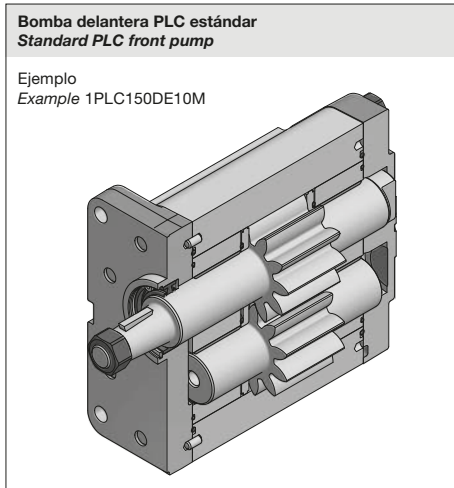

**NOTA:** Consultar las referencias disponibles con el departamento comercial. / **NOTE:** For available references contact the sales department.

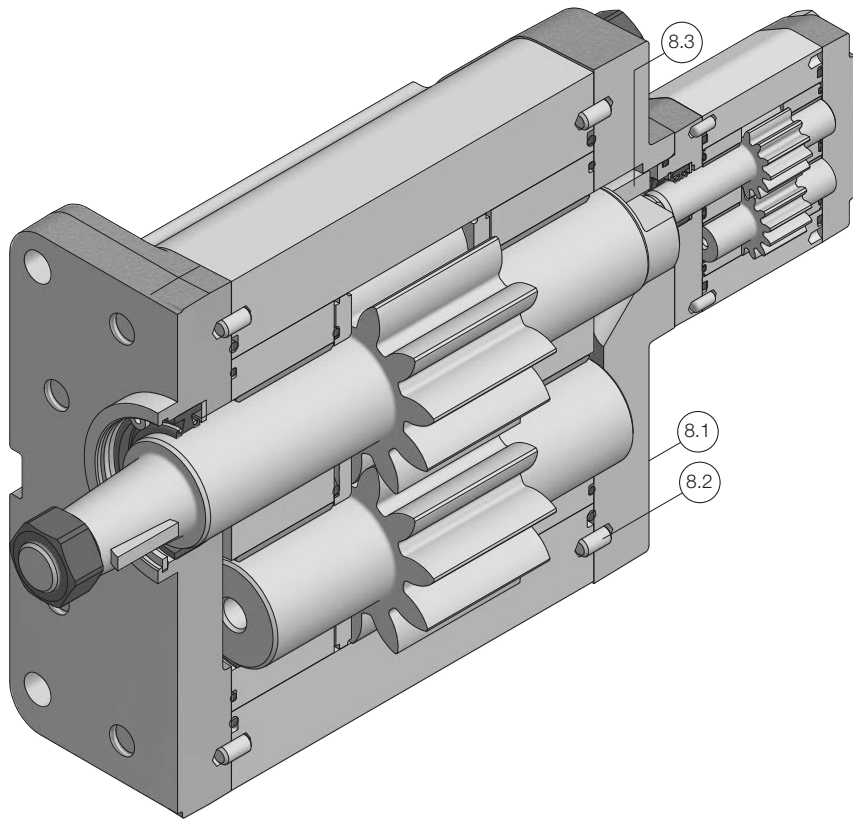

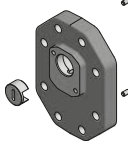
Nº de kit Kit number	Descripción Description	Piezas Parts
8	Kit tapa intermedia Intermediate flange kit	

**NOTA:** Se puede crear una bomba doble PLZ uniendo una bomba PLC estándar, un kit de tapa intermedia y una bomba L0 estándar con eje tipo B y tapa frontal tipo 24 (tapa tipo 22 + tornillos de fijación bomba posterior).

**NOTE:** A PLZ double pump can be assembled from a standard PLC pump, an intermediate flange kit and a standard L0 pump with shaft form B and front flange type 24 (front flange type 22 + rear pump fixing screws).

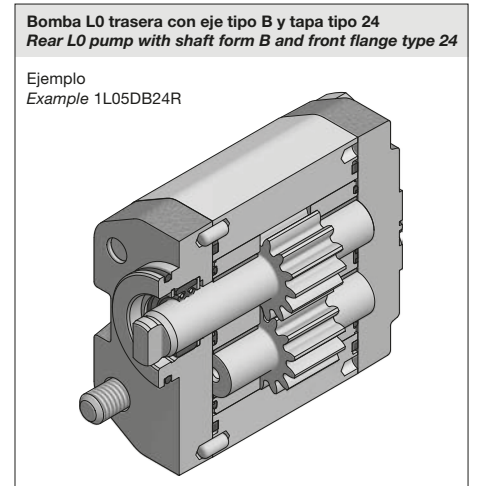
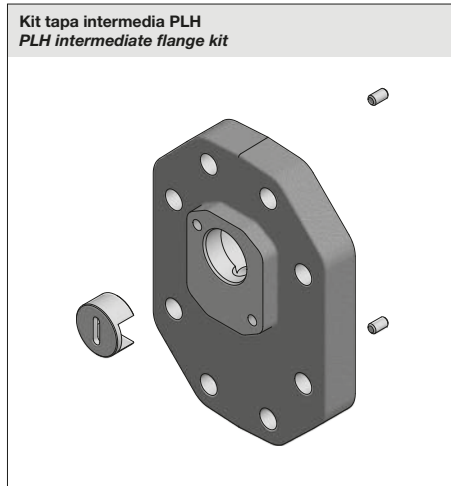
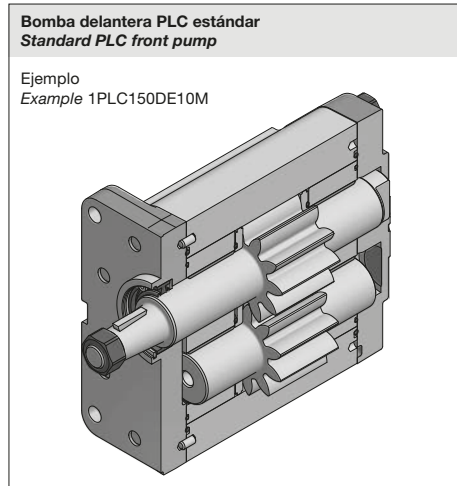

**NOTA:** Consultar las referencias disponibles con el departamento comercial. / **NOTE:** For available references contact the sales department.

**Roquet**  
*making moves*  
[www.roquetgroup.com](http://www.roquetgroup.com)